

## Fig No: DA-BFC200 / SR-BFC200

1/2" ~ 12" ( DN 15 ~ DN 300 )

DA: Double Acting SR: Spring Return



### Valve Specification :

**Wafer Type Butterfly Valve**

**Design Specification according to API 609**

Face to face according to API 609

Material : Stainless Steel, Carbon Steel, Ductile Iron or Cast Iron

Actuator Mounting in accordance with ISO 5211 direct mounting

Connection : JIS 10K/ ANSI 150/ PN 16

Working pressure :

	Working Pressure	Shell Testing Pressure
Cast Iron / ASME B 16.1	232 Psi (16 bar)	348 Psi (24 bar)
Ductile Iron / ASME B 16.42	250 Psi (18 bar)	375 Psi (27 bar)
Stainless Steel / ASME B 16.34	275 Psi (20 bar)	413 Psi (30 bar)

Seat temp. range:

MATERIALS	TEMP. RANGE
NBR (NITRILE)	-10° ~ 80° C (14° ~ 176° F)
EPDM	-20° ~ 120° C (-4° ~ 248° F)
NEOPRENE(CR)	0° ~ 80° C (32° ~ 176° F)
SILICON	-20° ~ 204° C (-4° ~ 400° F)
HYPALON (CSM)	-20° ~ 135° C (-4° ~ 275° F)
VITON	-18° ~ 204° C (-0.4° ~ 400° F)

### MATERIALS LIST

NO.	PART NAME	MATERIAL	QTY
1	BODY	CF8M / CF8 / WCB / CAST IRON / DUCTILE IRON	1
2	DSIC	CF8M / CF8 / CAST IRON / BRONZE	1
5-1	LOWER SHAFT	SS316 / SS410 / SS416	1
5-2	UPPER SHAFT	SS316 / SS410	1
6	FOLLOWER	BRONZE	1
9	SEAT	PTFE.	1
20	BOLT	SS304	4
22	LOCATING PIN	SS316	2
23	STEM BUSHING	EPDM / NBR / PTFE / VITON	3
24	O-RING	NBR / EPDM	2
39	PNEUMATIC ACTUATOR	ALUMINUM	1

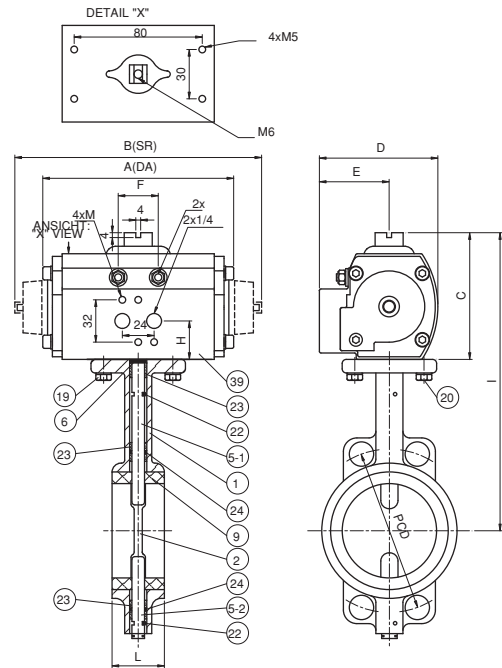

### DIMENSIONS

Unit:mm

SIZE	2"		2-1/2"		3"		4"		5"		6"		8"		10"		12"	
<b>Air Supply</b>	80 PSI		80 PSI		80 PSI		80 PSI		80 PSI		80 PSI		80 PSI		80 PSI		80 PSI	
<b>ACTUATOR</b>	DA	SR	DA	SR	DA	SR	DA	SR	DA	SR	DA	SR	DA	SR	DA	SR	DA	SR
	C-250	C-450 SR4	C-250	C-1000 SR2	C-250	C-1000 SR3	C-450	C-2250 SR3	C-1000	C-2250 SR4	C-2250	C-3650 SR4	C-2250	C-11000 SR3	C-3650	C-11000 SR4	C-5000	**
<b>P</b>	ANSI 150#	120.7	139.7	152.4	190.5	215.9	241.3	296.5	362.0	431.8								
<b>C</b>	DIN PN10/16	125.0	145.0	160.0	180.0	210.0	240.0	295.0	350.0	400.0								
<b>D</b>	JIB 10K	103.0	120.0	128.0	1605.0	191.0	215.5	268.0	324.0	401.0								
<b>A</b>	144.3	**	144.3	**	144.3	**	149.2	**	183.0	**	259.6	**	259.6	**	304.3	**	364.4	**
<b>B</b>	**	205.6	**	250.0	**	250.0	**	355.0	**	355.0	**	422.0	**	642.0	**	642.0	**	**
<b>C</b>	99.0	118.0	99.0	141.0	99.0	141.0	118.0	161.0	141.0	161.0	161.0	196.0	161.0	263.7	196.0	263.7	216.0	**
<b>D</b>	81.4	95.0	81.4	119.0	81.4	119.0	95.0	140.5	119.0	140.5	140.5	185.2	140.5	238.2	185.2	238.2	204.8	**
<b>E</b>	47.8	51.5	47.8	64.5	47.8	64.5	51.5	75.5	64.5	75.5	75.5	105.5	75.5	125.0	105.5	125.05	107.8	**
<b>F</b>	32.5	32.5	32.5	46.2	32.5	46.2	32.5	54.0	46.2	54.0	54.0	79.7	54.0	95.3	79.7	95.3	79.4	**
<b>G</b>	M5xP0.8	M6xP1.0	M5xP0.8	M8xP1.25	M5xP0.8	M8xP1.25	M6xP1.0	M10xP1.5	M8xP1.25	M10xP1.5	M10xP1.5	M12xP1.75	M10xP1.5	M16xP2.0	M12xP1.75	M16xP2.0	M12xP1.75	**
<b>H</b>	29.7	30.2	29.7	33.5	29.7	33.5	30.2	39.0	33.5	39.0	39.0	97.4	39.0	124.7	97.4	124.7	99.0	**
<b>I</b>	261.0	280.0	274.0	316.0	280.0	322.0	318.0	361.0	354.0	374.0	386.0	421.0	421.0	523.7	488.0	555.7	553.0	**
<b>L</b>	45.0		48.0		49.0		55.0		58.0		59.0		64.0		70.0		80.0	